



**EMDE**  
Automation

**AI**  
in FILLING

**worldwide unique technology**

# WORLD'S FIRST!

fully automatic big bag filling station



**NEW**  
we fill better!

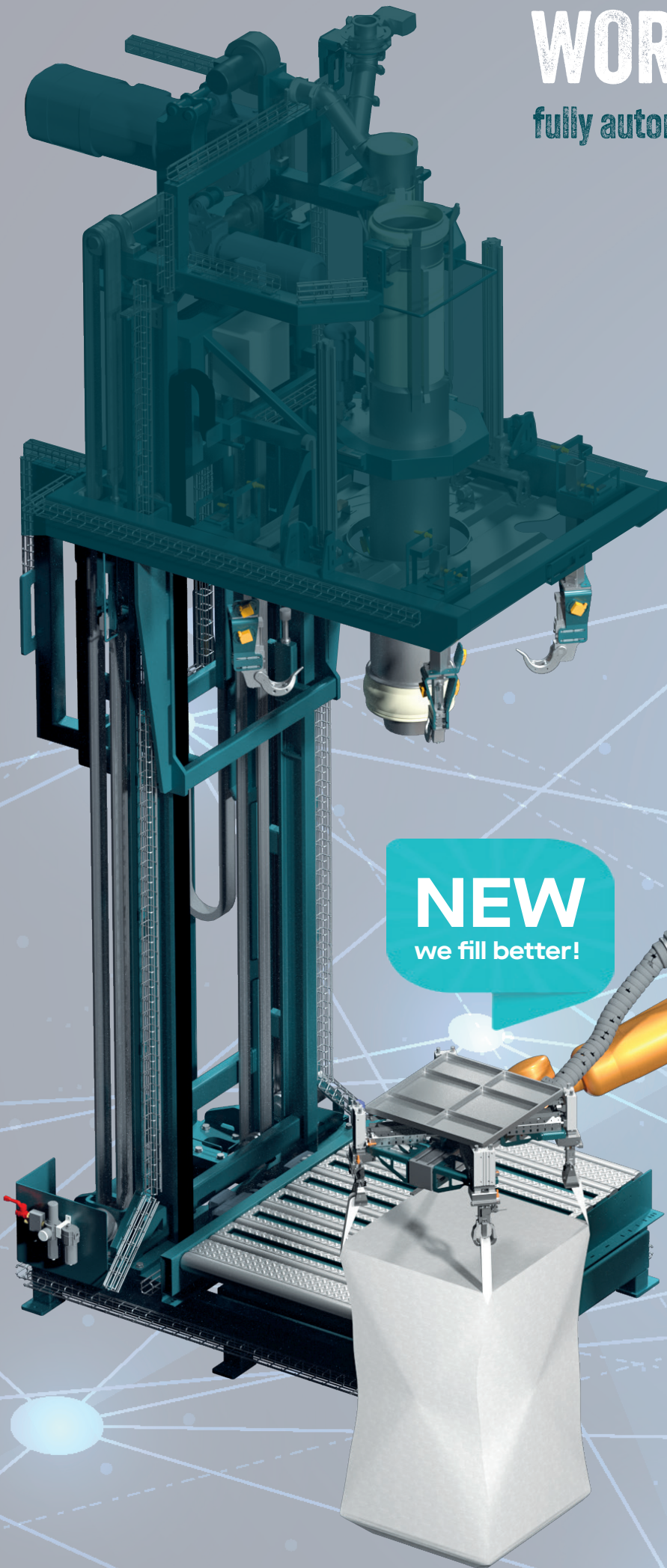

# Modular filling concept

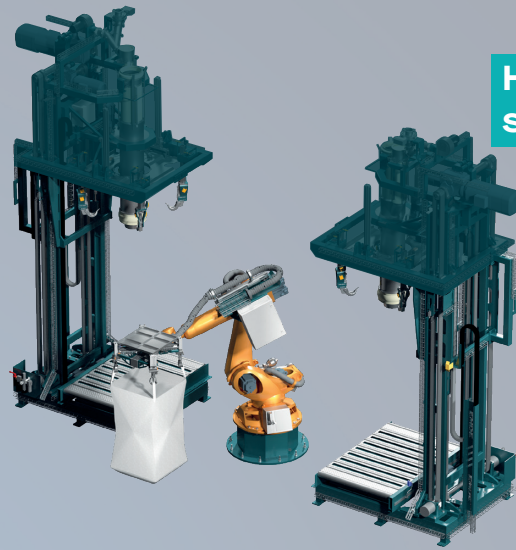

Handling for second filling station

## STEP 1: OPERATION

Pre-weighing hopper



Big Bag - Clipper

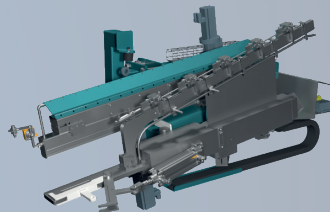

Big Bag magazine

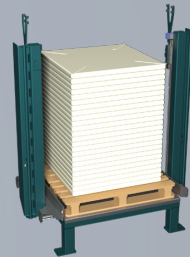

## STEP 2: TRANSPORT

Roller conveyor

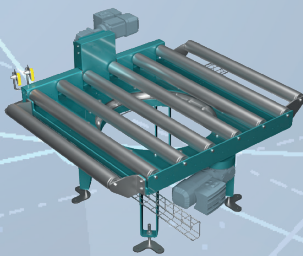

Pallet magazine

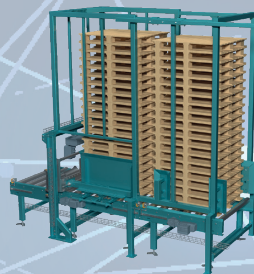

Paper applicator

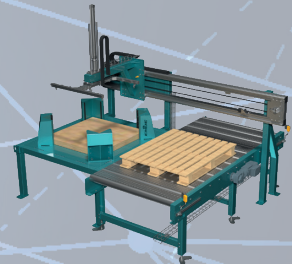

## STEP 3: SAFETY & ACCESSORIES

Safety fence

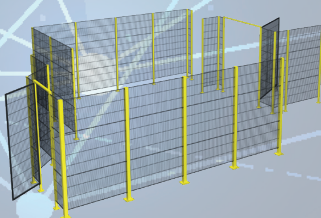

Metal detector



Label printer

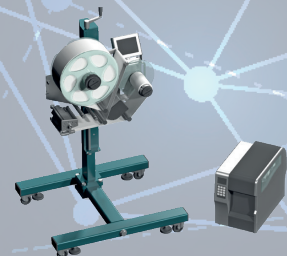



USP

## WE FILL BETTER



**modular system - create your plant as you need it**



**get all components from EMDE designed ready to use**



**scalable to requirements**



**globally unique new technology for efficient workflow fully automated**



**up to 50 big bags per hour in smallest version**



**big bag dimensions from 850-1100 mm x 850-1100 mm**



**big bag weights up to 1.500 kg**

### EMDE Group

EMDE has consistently developed over its 40-year history. From component manufacturer for, e.g., screw conveyors to plant manufacturer for big bag filling stations. Then, from plant manufacturer to solution specialist for technologically demanding systems.

Since then, our experiences have also increased our demands. Proof of this is our world-leading fully automated 4-loop big bag filling line.

As an innovative solution specialist, we develop tailor-made systems and components for conveying, dosing, mixing, filling and emptying bulk materials. We see it as our task to further develop your production concept with you – to implement it economically, future-proofed and networked.

**EMDE Automation GmbH**  
Koppelheck | 56377 Nassau

Phone.: +49 (0) 26 04 - 97 03 - 0  
info@emde.de | www.emde.de

FLS0015E