



YOUR COMPETENT PARTNER  
FOR SOLIDS HANDLING!



Big Bag emptying stations



1 Big Bag emptying stations for the charging of differential metering scales

## The flexible solutions for each Big Bag ...

The room heights, which are often very low, and the different Big Bag forms as well as the product characteristics represent significant challenges for project related individual solutions.

- Building block principle that can be combined individually
- Intelligent solutions for all Big Bag variants
- Operator friendly and space oriented individual solution
- Clean and safe Big Bag handling
-  - protected design for dust and gas ex-proof areas



2 Big Bag emptying station in Batchbin system



3 Big Bag emptying station with connected EMDE-LIFT

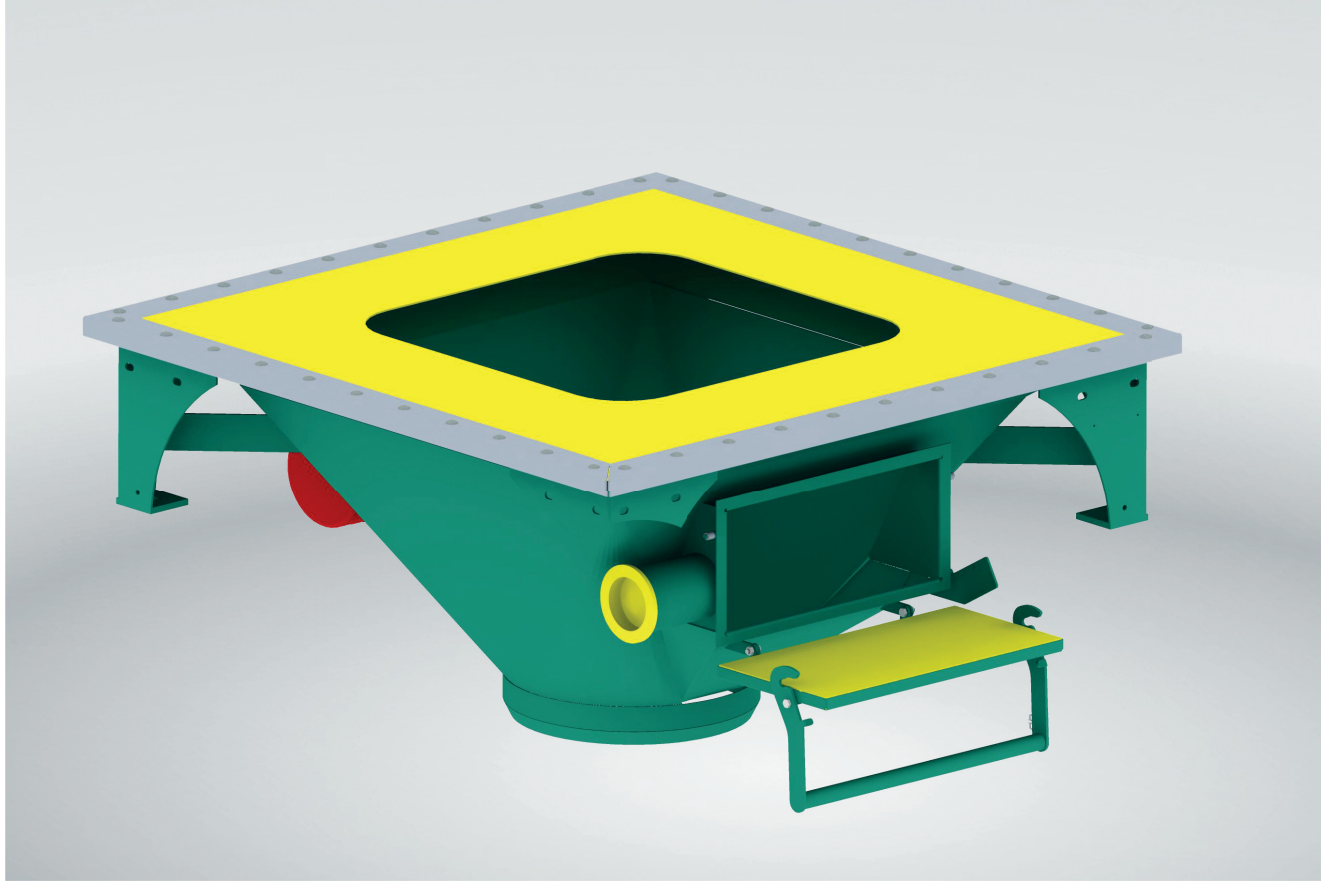

4 Type BE 1500

## ... and dust free, of course

Utilizing the building blocks principle, the different systems can be combined with required discharge supports, supporting frame designs adapted to the local conditions and Big Bag traverses. Each type is characterized by the following system advantages:

### Type BE 1000

- Product discharge into open discharge funnel
- Easily controllable emptying process
- Easily accessible and quickly cleaned

### Type BE 1400

- Fixed connection for the discharge adapter
- Easy closing of the bag clamp
- Dust collection bowl for clean handling

### Type BE 1500

- Universal solution for all Big Bag variants
- Safe untying across large operating opening
- Dust-proof rubber membrane for Big Bag bottom

### Type BE 1600

- Dust-proof docking of the discharge
- Optimal product discharge with re-tightening
- Fixation of the discharge with inner inflating hose

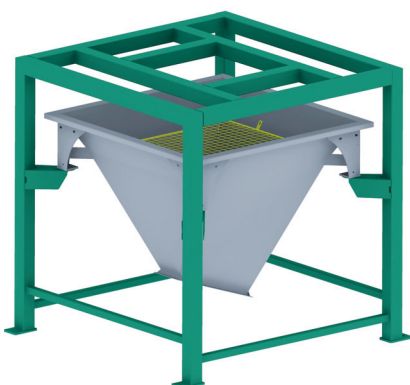

5 Type BE 1000 with safety protection support

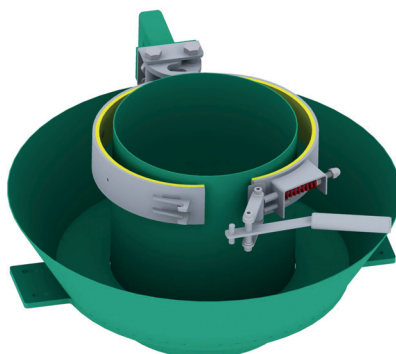

6 Type BE 1400

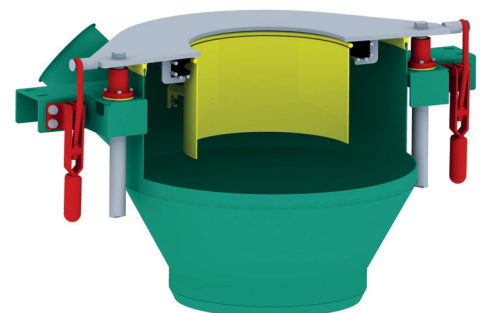

7 Type BE 1600



8 Combined bag/big bag emptying station in final assembly

## Supporting frame for all applications

### Variant „S“

#### Frame for fork lift charging

- Frame with centering edges for safe traverse support
- Frame heights divided above 5 m, with flange connection



9

### Variant „P“

#### Frame with integrated chain hoist

- Chain hoist with electrical carriage
- Big Bag tensioning possible during emptying
- Fork lift independent operation



10



11 Big Bag emptying station with movable carrying frame

## ... also for low room heights

### Variant „HST“; Lift column with movable carrying frame

- Automatic Big Bag positioning
- Complete utilization of the room height
- Lift column height freely selectable



12

### „HSS“ variant; swiveling Lift column with electrical chain hoist

- Manually swiveling lift columns with electrical chain hoist
- Ideal solution for low room heights



13



14 Special traverse with automatic loop release

## Big Bag traverses for all applications

- Load handling device with static proof
- Test book with proof of the static test
- Conformity declaration in accordance with machine directive 2006 / 42 / EC

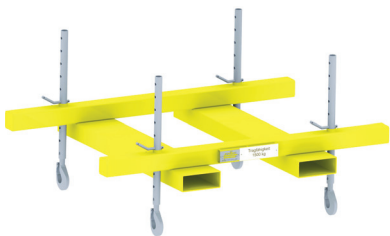

15

Traverse for  
fork lift operation

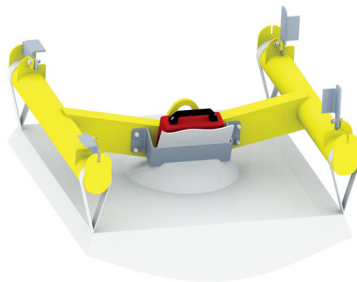

16

Traverse for crane operation  
with liner clamping device

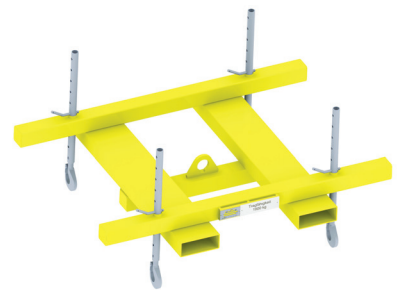

17

Traverse for  
crane & fork lift operation

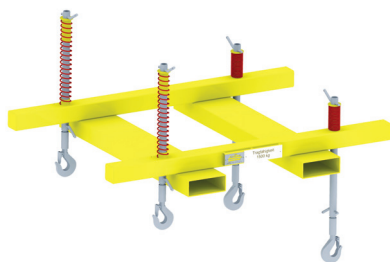

18

Fork lift traverse with  
spring loaded load hook for  
Big Bag re-tensioning



19

Crane traverse with  
loop deflection



20 Big Bag emptying station with vibration discharge bottom and downstream metering screw

## The universal variant BE 1500

This design, which has been proven many times during the last decades, can be used to empty all Big Bag designs and sizes safely and with little dust. The exchangeable and tear-resistant rubber membrane of the discharge funnel guarantees a dust-proof connection to the Big Bag bottom. A very clean handling is possible if the discharge funnel is de-dusted at the same time through the aspiration adapter at the operating door.

- Universal solution for all Big Bag variants
- Displacement funnel with dust-proof rubber membrane in the direction of the Big Bag bottom
- Operating opening with large dimension
- Quick release flap with ergonomic single hand bracket lock



21 Inliner clamping device



22 Cross blades

23 Attached filter and dust return



24 Big Bag emptying station type BE 1500 HSS with lift/swiveling column

## ... fits each Big Bag

The basic form of the open discharge funnel is adapted to the geometry of the Big Bag, which is in most cases square and it enables an individual elongation of the Big Bag during the emptying process. When lifting the emptied Big Bag, the dust residues will be fed safely into the material flow before the discharge spout is tied.

- Opening of Big Bags with closed bottom by using a cross blade
- Big Bag bottom activation through vibration support of the discharge funnel
- Filter system with dust return in discharge funnel



25 Type BE 1500 with dust aspiration duct

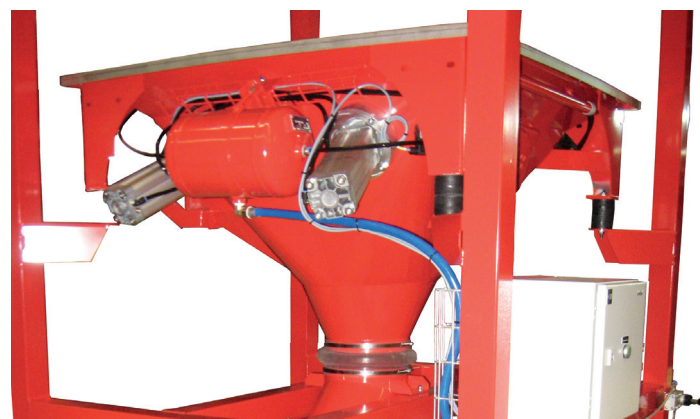

26 Bottom massaging device with valve control



27 Big Bag emptying station BE 1600 HSS

## Dust proof connection - Type BE 1600

A dust proof connection of the discharge hose with the emptying station through a dual ring docking system with pneumatic or manually actuated docking plate guarantees a very clean and dust free operation.

- Dust free connection of the Big Bag discharge spout
- Targeted aspiration of the closed docking system
- Evacuation of the Big Bag possible after emptying
- Ergonomic hand lever lock or pneumatic actuation of the docking plate
- Optimal Big Bag emptying through pneumatic re-tensioning equipment of the docking system
- Inner inflatable hose in docking plate additionally secures and seals the discharge hose



28 Dust proof connection discharge spout Big Bag



29 Docking system BE 1600

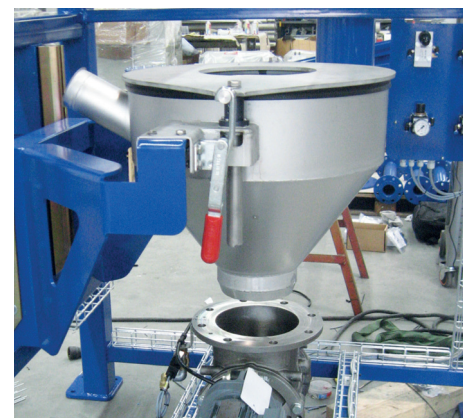

30 Docking plate with hand lever tighteners



31 Big Bag emptying station BE 1000 S with discharge screw

## Easy handling - type BE 1000 and BE 1400

These Big Bag emptying variants guarantee a very fast and straightforward handling for the safe emptying of Big Bags. The discharge hose is easily accessible for untying. The system BE 1000 is often used for the emptying of Big Bags with a closed bottom. The Big Bag bottom will be completely cut open using a cross blade with puncture point.

- Very ergonomic untying of the discharge hose
- Type BE 1000 ideal for Big Bags without discharge spout
- Cross blade with four blades with puncture point and exchangeable blades
- Type BE 1400 with tightly closing single hand bag clamp and dust collection bowl



32 Type BE 1400 with discharge lock system



33 Bottom massaging device

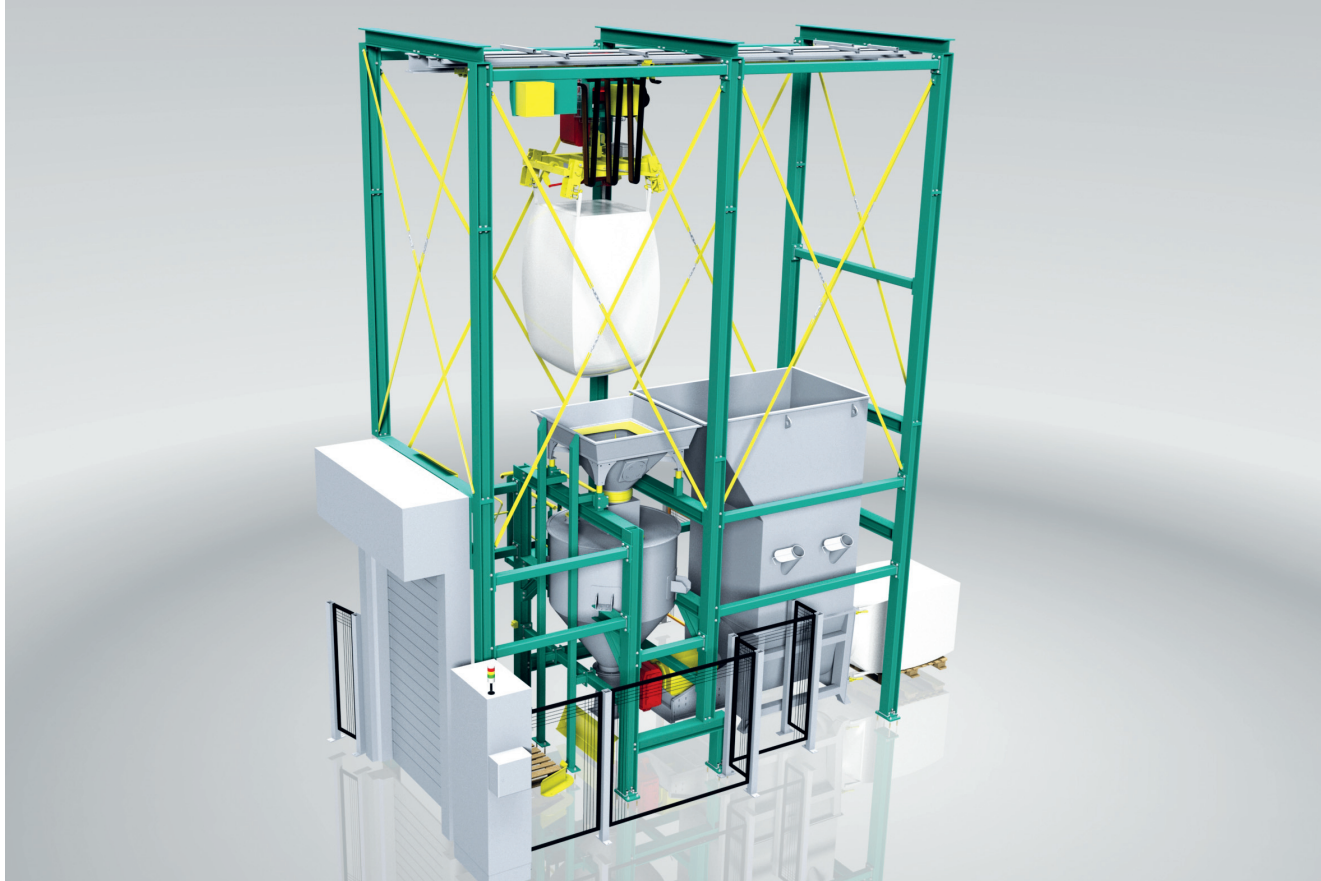

34 Automatic Big Bag emptying system

## Automatic emptying

Even mass products are transported in Big Bags. We offer complex solutions for Big Bag handling or for the automatic slicing and for the low dust disposal of the empty package for a largely automatic and dust-free emptying of large volumes or harmful materials.

- Handling of the Big Bags through a crane system with a distance coding system
- Automatic slicing of the bottom via cross blades or actuated circular knife
- System housing and targeted dust aspiration guarantee a dust free process



35 Big Bag compressor in automatic emptying system



36 Big Bag bottom sliced open on 3 sides



37 Guided circular knife



38 Side massaging device in Big Bag emptying system

## Emptying ... based on proven discharge supports

We call it an emptying station if it is guaranteed that the Big Bag is emptied! Practice proven discharge supports guarantee the above:

- Discharge bottom with electrical vibrator
- Bottom massaging device with 4 massaging cones to activate the Big Bag bottom
- Side massaging device with press bars top brake crustifications open
- Re-tensioning device for discharge spout
- Fluidization equipment
- Traverse with inliner clamping equipment



**Nassau plant**

Koppelheck ♦ D-56377 Nassau

Phone +49 (0) 26 04 - 97 03 - 0

**[www.emde.de](http://www.emde.de)**

